



BOSCH

Installation Manual and Operating Instructions

Continuous Flow Gas Water Heaters (External Models)

Pilot Ignition

TF250... | TF400...

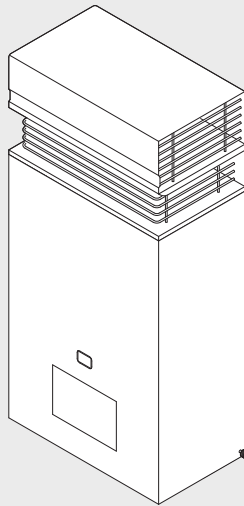



Table of contents

1	Safety information and symbols	3	6.3	Water flow adjustment	15
1.1	Key to symbols	3	6.4	Inlet operating pressure adjustment	15
1.2	Safety information	3	6.5	Burner pressure adjustment	16
<hr/>			6.6	Thermostat calibration	16
2	Technical Characteristics and Dimensions	5	6.7	Conversion to a different type of gas	16
2.1	General Description	5	<hr/>		
2.2	Explanation of Model Code	5	7	Operating instructions	17
2.3	Package contents	5	7.1	Procedure to light 10 Litres appliance	17
2.4	Description of the Hot Water Unit . . .	5	7.1.1	Lighting the appliance	17
2.5	Dimensions	6	7.1.2	Output control	17
2.6	Technical characteristics	7	7.1.3	Consumer temperature/flow adjustment	17
<hr/>			7.1.4	Shutting OFF the appliance	17
3	Regulations	8	7.2	Procedure to light 16 Litres appliance	18
<hr/>			7.2.1	Lighting the appliance	18
4	Installation	8	7.2.2	Shutting OFF the appliance	18
4.1	Important information	8	<hr/>		
4.2	Requirements of the installation location	10	8	Maintenance	19
4.3	Hot Water Unit mounting	11	<hr/>		
4.3.1	Flue baffle setting	11	9	Troubleshooting	20
4.3.2	Mounting the heater	11	9.1	Problem/cause/solution	20
4.4	Water connection	12	<hr/>		
4.5	Gas connection	12	10	Environmental protection	22
4.6	Testing	12	<hr/>		
<hr/>			11	Water quality	22
5	Commissioning 10 litres appliances	13	<hr/>		
5.1	Before starting up the heater	13	12	Warranty details	23
5.2	Remove the front cover	13	<hr/>		
5.3	Inlet pressure adjustment	13			
5.4	Burner pressure adjustment	13			
5.5	Conversion to a different type of gas	14			
<hr/>					
6	Commissioning 16 litres appliances	15			
6.1	Before starting up the heater	15			
6.2	Remove the front cover	15			

1 Safety information and symbols

1.1 Key to symbols

Warnings

	<p>Warnings in this document are identified by a warning triangle printed against a grey background.</p> <p>Keywords at the start of a warning indicate the type and seriousness of the ensuing risk if measures to prevent the risk are not taken.</p>
--	---

The following keywords are defined and used in this document:

- **NOTICE** indicates a situation that could result in damage to property or equipment.
- **CAUTION** indicates a situation that could result in minor to medium injury.
- **WARNING** indicates a situation that could result in severe injury or death.
- **DANGER** indicates a situation that will result in severe injury or death.

Important information



This symbol indicates important information where there is no risk to people or property.

Additional symbols

Symbol	Explanation
▶	Step in an action sequence
→	Cross-reference to another part of the document
•	List entry
–	List entry (second level)

Table 1

1.2 Safety information

If you smell gas:

- ▶ Close the gas supply valve to the appliance.
- ▶ Isolate gas supply from gas meter or LPG bottle.
- ▶ Do not operate any electrical appliances or switches (on/off).

- ▶ Extinguish other sources of ignition.
- ▶ Go to a different location and call the gas supplier or an authorised technician in order to check the gas supply.

If you notice dark combustion gases or sooting:

- ▶ Isolate the Gas supply to the heater.
- ▶ Notify an authorised technician.

Installation, Assembly and Modifications

- ▶ The installation, assembly and modifications to the heater must only be performed by an authorised installer.

Maintenance

- ▶ The water heater is required to have a service and safety inspection every two years.
- ▶ The Installer is responsible for the safety and environmental compatibility of the installation.
- ▶ The Owner/User is responsible for keeping the area around the water heater free from debris.
- ▶ Safe access to inspect and service the water heater is the responsibility of the property owner.
- ▶ Only original spare parts must be used, supplied by an authorised distributor of Genuine Bosch parts.

Explosive and highly flammable material

- ▶ Do not use or store flammable materials in or near this appliance.

Combustion air and surrounding air

- ▶ To avoid corrosion, the combustion air and surrounding air must be free from harmful substances.
- ▶ Do not spray aerosols in the vicinity of this appliance while it is in operation.

Risk of damage due to operator error

Operator errors can result in injury and damage to property.

- ▶ Ensure that children never operate this appliance unsupervised.
- ▶ Ensure that only personnel who can operate this appliance correctly have access to it.
- ▶ Refer to the operating and user instructions before adjusting the water heater.

To be installed and serviced only by an authorised person

The “authorised installing person” is responsible for:

- ▶ Correct installation and commissioning of this appliance.
- ▶ Ensuring the appliance performs to the specifications stated on the rating label.
- ▶ Demonstrating the operation of the appliance to the customer before leaving.
- ▶ Handing these instructions to customer.

THIS APPLIANCE IS NOT SUITABLE FOR POOL, SPA POOL OR SOLAR BOOSTER APPLICATION.

NOT SUITABLE FOR COMMERCIAL BOOSTING OF A WARM WATER RECIRCULATION SYSTEM.

Do not modify this appliance.



WARNING:

This appliance may deliver water at high temperature. Refer to the Plumbing Code of Australia (PCA), local requirements and installation instructions to determine if additional delivery temperature control is required.

2 Technical Characteristics and Dimensions

2.1 General Description

The appliance has been AS/NZS 5263.1.2 tested.

Models	TF250/400
Category	CONTINUOUS FLOW
Type	GAS - EXTERNAL INSTALLATION

Table 2

2.2 Explanation of Model Code

TF (Top Flue)	250 (10 litres/min @ 25 °C Rise)
TF (Top Flue)	400 (16 litres/min @ 25 °C Rise)

Table 3

2.3 Package contents

- Gas hot water unit
- Documentation

2.4 Description of the Hot Water Unit

- Hot Water Unit for external wall-mounting only
- Available in Natural gas or LP gas
- Safety devices:
 - Thermocouple to check for accidental extinction of the pilot flame
 - Overtemperature switch to prevent overheating.
- Water filter on the inlet water supply

Economical

Only heating water when required, the Bosch range is extremely economical to run.

Versatile

LPG models are particularly popular in country areas, where Natural Gas is not available.

Low Temperature Areas

In areas where the atmospheric temperature may drop to 0 °C for brief periods, the installation of an EXOGEL valve (part number H707 060 151) will minimise the possibility of damage to the appliance if the water freezes.

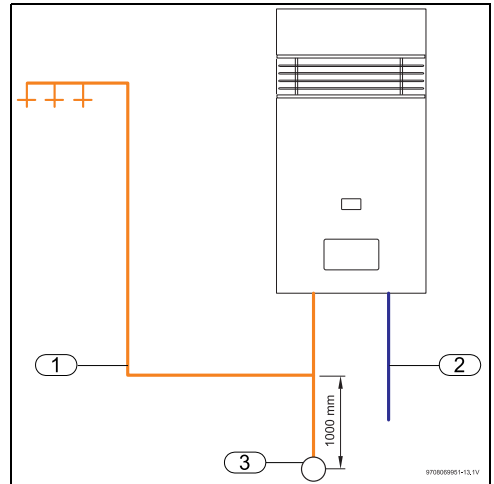

Fig. 1 EXOGEL valve

- [1] Hot water
- [2] Cold water
- [3] EXOGEL valve

Low Flow Rates

This gas water heater is designed to operate at a minimum flow rate between 3.2 to 4.0 litres per minute. Sufficient flow must be provided to ensure the correct operation of the appliance.

There are various causes of a low flow rate including, but not limited to:

- Low flow tapware
- Flow restrictors/aerators
- Hand held showers
- Poor inlet pressure to property
- Restrictive pipework and/or fittings

Water fixtures and appliance settings must ensure that the flow rate of hot water does not fall below the minimum requirement.

Failure of the unit to operate correctly due to poor flow rate will not be covered by warranty.



NOTICE:

This water heater **MUST NOT** be installed in areas where the temperature remains below 0 °C for extended periods.

2.5 Dimensions

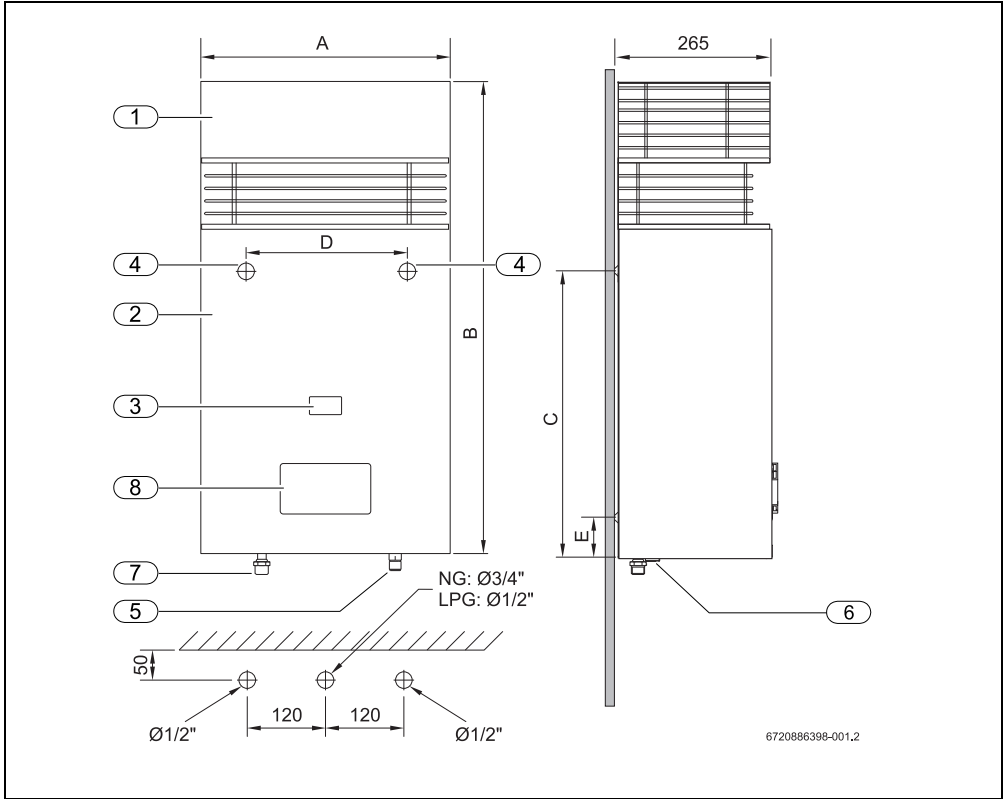

Fig. 2

- | | |
|-------------------------|----------------------|
| [1] Top flue | [5] Cold water inlet |
| [2] Front cover | [6] Gas inlet |
| [3] Inspection window | [7] Hot water outlet |
| [4] Wall mounting point | [8] Access panel |

Dimensions (mm)	A	B	C	D	E	Weight (kg)
TF250	405	845	533	240	100	21
TF400	460	936	533	240	100	25

Table 4 Dimensions

2.6 Technical characteristics

Technical characteristics	Units	TF250...	TF400...
Gas Consumption			
Nominal Gas Consumption	MJ/h	82	130
Ø burner injector	mm	1.20 (NG) 0.75 (LPG)	1.30 (NG)
Supply pressure flowing			
Natural gas (When operating)	kPa	1.13	1.13
LP gas (When operating)	kPa	2.6	2.6
Number of injectors		12	18
Water data			
Maximum permissible pressure (Static)	kPa	1200	1200
Temperature selector in fully clockwise position			
Temperature rise (Above incoming water temperature)	°C	55	–
Water flow range (Litres per minute)	l/min	3.5 to 4.5	–
Minimum operating water pressure	kPa	30 (NG) 10 (LPG)	– –
Minimum constant water pressure for minimum flow	kPa	60	–
Temperature selector in fully anti-clockwise position			
Temperature rise (Above incoming water temperature)	°C	25	–
Water flow range (Litres per minute)	l/min	4 to 10	–
Minimum operating water pressure	kPa	45	–
Minimum constant water pressure for maximum flow	kPa	90 (NG) 55 (LPG)	–

Table 5

3 Regulations

All local by-laws and regulations pertaining to installation and use of gas appliances must be observed.

This appliance must be installed in accordance with the manufacturers installation instructions, AS/NZS5601, AS/NZS3500 and all Local Building & Gas fitting regulations.

This appliance must not be installed indoors or in an enclosed space. This appliance is approved for outdoor installation only.

Failure to install this appliance in accordance with these installation instructions will void the warranty and may create an unsafe situation.

4 Installation



DANGER:

This appliance must not be installed indoors or in an enclosed space in accordance with AS/NZS5601.



DANGER: Explosion Risk!

- ▶ Always turn off the gas valve before carrying out any work on components which carry gas.



DANGER: Appliance malfunction!

This appliance must be installed with no obstructions to air entry openings at the front, rear, side, or top.

- ▶ Periodic checking of openings to ensure no blockage or obstruction of the air openings from plants, debris, or insects must be carried out.



DANGER: Property damage!

If this appliance is to be installed on a combustible surface:

- ▶ Use a heat shield as per AS/NZS5601.

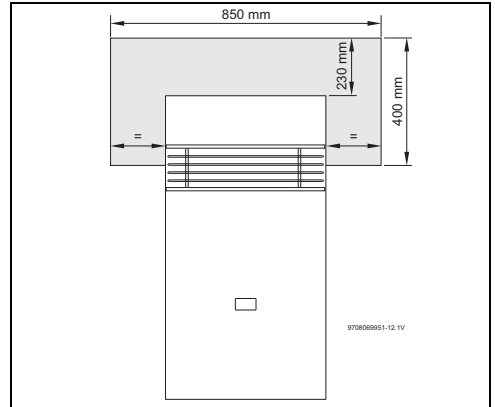

Fig. 3 Minimum heat shield requirements



The installation and the initial startup are to be carried out only by an authorised person.



Not suitable for pool, spa pool, or solar booster application.
Not suitable for commercial boosting of a warm water recirculation system.



This appliance should only be installed in applications where incoming cold water temperature does not exceed 40 °C.



Minimum water supply pressure must meet the requirements set out in table 5.
Water fixtures and appliance settings must ensure that the flow rate of hot water does not fall below the minimum requirement.



To reduce the chance of corrosion, installation in a marine environment should be avoided. Premature corrosion due to the installation environment would not be covered by warranty.



All gas appliances require adequate air intake to ensure correct combustion. Insects and dirt ingress may affect combustion causing sooting. If you notice sooting from the flue outlet the unit would require servicing.

Pest and dirt ingress is not covered by the manufacturers warranty.

- ▶ As the water temperature at the outlet may exceed 50 °C, a temperature limiting device (such as a tempering valve) must be fitted to pipework feeding sanitary fixtures used for the purpose of personal hygiene as per AS3498.

Note: Incorrect pipe sizing or gas supply pressure may cause the appliance to underperform. Service calls for incorrect pipe sizing and/or gas pressure, will NOT be covered under warranty.

4.1 Important information

- ▶ Determine most suitable location for the appliance. Install only on an external wall as close as possible to the most frequently used hot water outlet. If the unit is to be installed on a combustible surface, use a heat shield. Allow a minimum air gap of 10mm between the flue and the heat shield.
- ▶ Unit must be commissioned upon installation.
- ▶ Ensure the mounting structure is capable of supporting the weight of the appliance once installed. Secure the appliance to the wall using fixings suitable for the weight of the appliance and the wall material.
- ▶ Do not place articles on or against this appliance.
- ▶ Install gas and water isolation valves as close as possible to the heater. Only use gate valve or full flow ball valve (fixed mechanism type) for cold water.
- ▶ Check the cold water supply pressure to ensure it meets the required supply pressure for the appliance. (→table 5).
- ▶ If the inlet water pressure exceeds 800 kPa, a pressure limiting valve (500 kPa) MUST be fitted. The preferable location for the pressure limiting valve is at the water meter.
- ▶ Where the pressure limiting valve is less than 3 metres from the hot water unit, it must be fitted in conjunction with a cold water expansion valve (700 kPa), between the water heater and the pressure limiting valve.
- ▶ Failure to comply with this requirement may void the warranty.
- ▶ Refer to AS/NZS5601 for the relevant gas pipe sizing.
- ▶ After finishing the gas piping system, the pipes must be thoroughly purged and leak tested. This test must be performed with the gas isolation valve of the appliance closed.
- ▶ Ensure the gas pressure and flow through the regulator are appropriate for the consumption of the heater (→table 5). Refer to AS/NZS5601 and AS3500.1 for the relevant pipe size.

4.2 Requirements of the installation location

- Comply with the specific instructions for each State.
- Install the appliance in an outdoor location where it will not be exposed to temperatures below zero.
- Install the appliance in accordance with the minimum installation clearances indicated in Fig. 4, according to AS/NZS5601.
- The gas heater must not be installed over a heat source.
- Location must allow for safe servicing and customer operation.
- Side clearances to be measured from flue outlet, not wind baffles.
- Do not obstruct the openings at top, bottom and rear of appliance.
- Maximum of 2 meters from the ground to the base of the appliance.
- Top and bottom areas must be clear from any obstacles at least 30 cm.

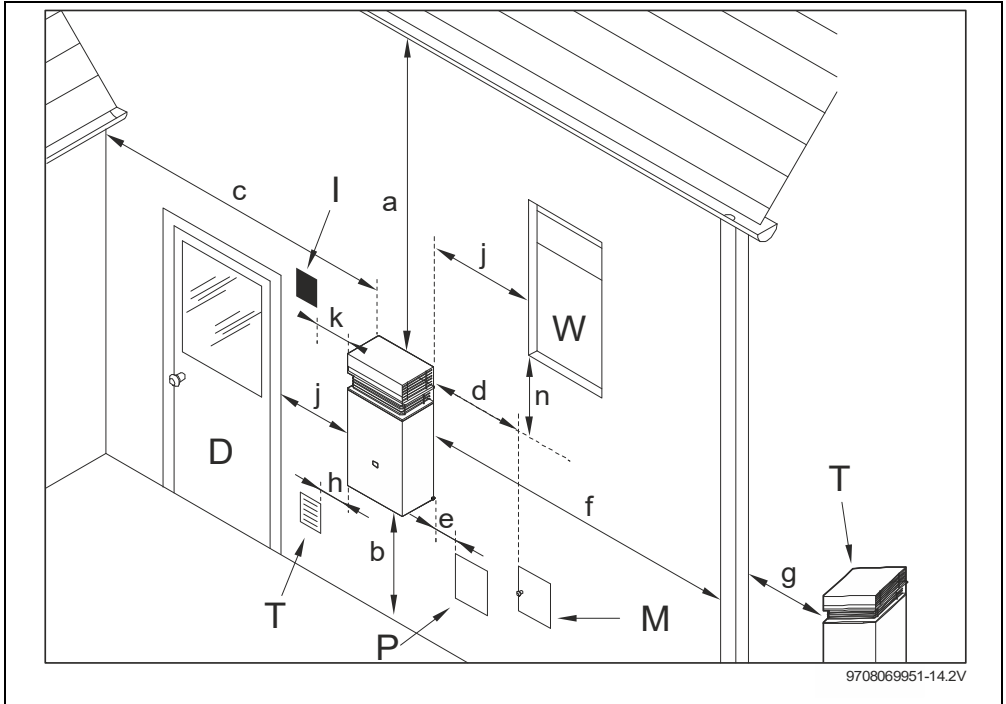

Fig. 4 Minimum clearances (use as a guide only, always refer to AS/NZS5601)

- [D] Openable Door
- [T] Flue terminal
- [M] Gas meter
- [I] Mechanical air inlet
- [P] Electricity meter or fuse box
- [W] Openable window

Ref.	Item	Minimum clearances (mm)
a	Below eaves, balconies and other projections: - Appliances over 50 MJ/h input	500
b	From the ground, above a balcony or other surface ¹⁾	300
c	From a return wall or external corner ¹⁾	500

Table 6

Ref.	Item	Minimum clearances (mm)
d	From a gas meter (M) (see 5.11.5.9 of AS/NZS5601 for vent terminal location of regulator)	1000
e	From an electricity meter or fuse box [P]	500
f	From a drain pipe or soil pipe	150
g	Horizontally from any building structure ¹⁾ or obstruction facing a terminal	500
h	From any other flue terminal, cowl, or combustion air intake [T] ¹⁾	500
j	Horizontally from an openable window, door, non-mechanical air inlet, or any other opening into a building with the exception of sub-floor ventilation [W] [D] [T]: - Appliances up to 150 MJ/h input	500
k	From a mechanical air inlet, including a spa blower [I]	1500
n	Vertically below an openable window, non-mechanical air inlet, or any other opening into a building with the exception of sub-floor ventilation [W] [T] - Appliances over 50 MJ/h input and up to 150 MJ/h input	1000

Table 6

1) Unless appliance is certified for closer installation

Combustion gases



Observe/comply with the minimum clearances as in AS/NZS5601.

4.3 Hot Water Unit mounting



CAUTION:

Property damage!

- ▶ Never rest the gas heater on the water or gas connections.

4.3.1 Flue baffle setting

The flue baffle located on the side of the flue terminal must be extended fully to ensure correct operation.

To extend baffle loosen the retaining nut and pull the baffle until it is fully extended. Tighten retaining nut.

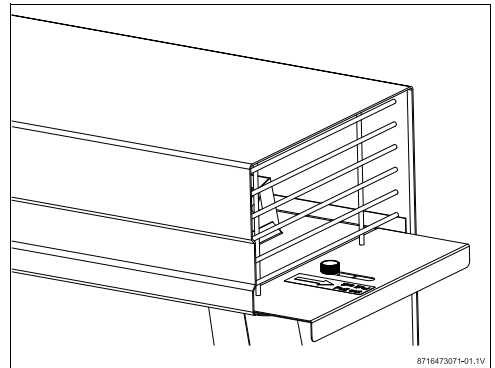

Fig. 5 Flue baffle setting

4.3.2 Mounting the heater

- ▶ Fix the appliance vertically, using the fixings appropriate for the wall material and appliance weight.



Draw a cross in the wall (→ Fig. 6, [A]) to identify the appliance upper right corner positioning.

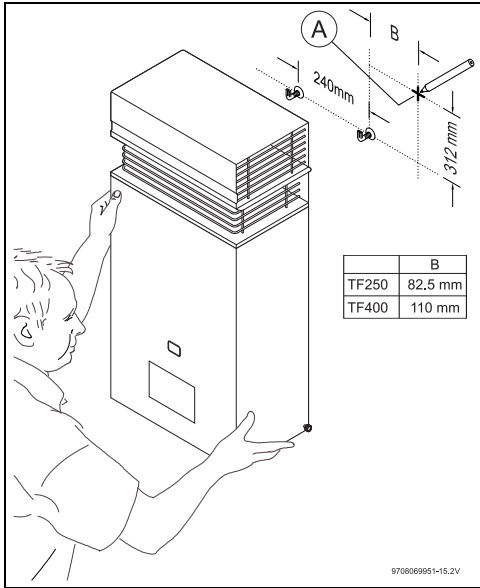

Fig. 6 Heater mounting

[A] Appliance upper right corner position

4.4 Water connection

Purge the water pipes before connection, because the presence of dirt may reduce the flow and, in extreme cases, cause a blockage.

- ▶ Identify the cold water pipe and the hot water pipe, so as to avoid any possible cross-connection.
- ▶ Check and ensure water filter cleanliness.

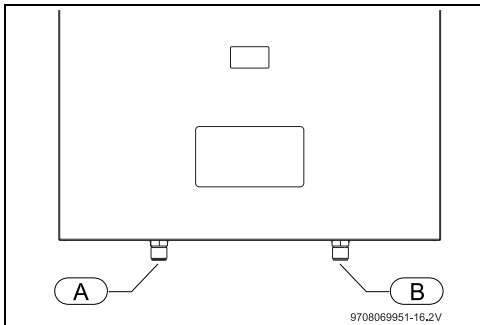

Fig. 7 Water connection

[A] Hot Water Outlet
[B] Cold Water Inlet

CAUTION:
Isolating valve on the water inlet line must be a Gate or ¼ turn full flow Ball Valve. A Stop Valve, Duo Valve or Non-Return Valve must not be fitted.

4.5 Gas connection

DANGER:
If local regulations are not followed, a fire or explosion could result causing property damage, personal injury, or loss of life.

Size gas supply as per AS/NZS5601.
Incorrect gas pipe sizing will not be covered by the warranty.

Gas regulator

The appliance is supplied with a gas pressure regulator already installed. A regulator must be fitted to LPG cylinders to supply the correct pressure to the appliance regulator.
The gas pressures require setting upon installation.

- ▶ Open all water and gas isolation valves.
- ▶ Purge the pipes.

4.6 Testing

- ▶ Turn on the gas and water valves and check all connections for leaks. If all connections are sound then follow procedures set out in Section 5 for adjustment of Gas Pressures to complete appliance commissioning.

5 Commissioning 10 litres appliances



Commissioning **MUST** be carried out upon installation.

5.1 Before starting up the heater



CAUTION:

- ▶ Initial startup must be performed by an authorised gas fitter who will provide the customer with all the necessary information for optimum operation of the gas heater.

5.2 Remove the front cover

- ▶ Loosen the two knurled screws located on the rear side of the front panel.

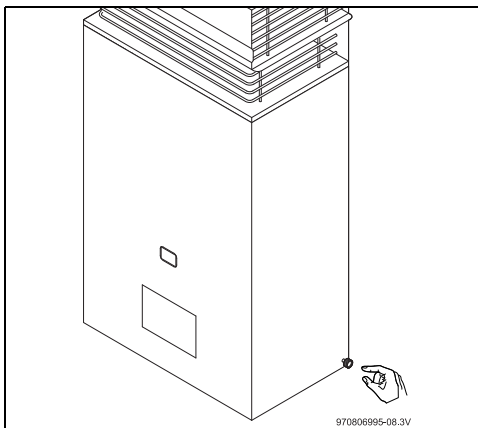

Fig. 8 Front cover removal

5.3 Inlet pressure adjustment



DANGER:

The following procedures must only be performed by a qualified technician.

Gas pressure adjustment (commissioning) **MUST** be carried out upon installation.

- ▶ Check the gas indicated on the data plate and label on the front flue panel is the same as to which the gas is connected.

- ▶ Turn off the gas to the appliance, remove the sealing screw of the pressure test point on the right hand side of the gas valve (Fig. 9, [A]) and attach a manometer.
- ▶ Turn on gas and light the pilot.

Static Pressures should be greater than or equal to the figures in table 7.

- ▶ Adjust the appliance regulator to achieve the figures in table 7 with the unit operating and several hot water taps open for full water flow through the unit.

If the operating inlet pressure cannot be achieved there may be an issue with the gas supply meter (NG), cylinder regulator (LPG), or pipe sizing (Ref AS/NZS5601). This must be resolved before proceeding.

- ▶ Remove manometer and tighten test point screw.



Measurements should be made with unit operating with several hot water taps opened to achieve maximum water flow through the unit.

If possible all other gas appliances (ducted heating etc.) should be operating at the same time.

		Natural gas	LP gas
Inlet Pressure (kPa)	TF250	1.13 kPa	2.6 kPa

Table 7 Inlet pressure

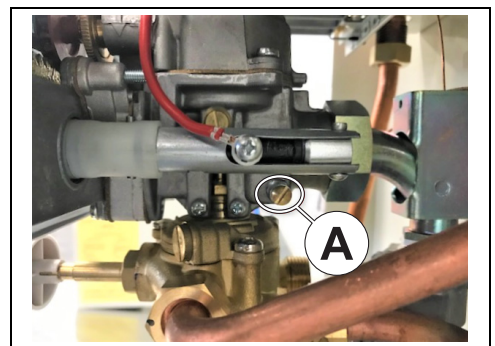

Fig. 9 Inlet measurement test point

5.4 Burner pressure adjustment

- ▶ Loosen the burner test point captive screw (→ Fig. 10 [D]).
- ▶ Connect a manometer to the burner pressure measuring point.

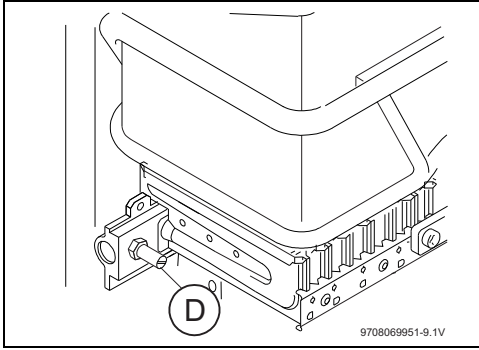

Fig. 10 Burner pressure test point

- ▶ Turn on gas to the appliance and relight the pilot.
- ▶ Ensure water control knob is wound fully clockwise (minimum flow) and gas control slide set to the right (maximum gas flow).
- ▶ Turn on the water heater with several hot taps open.
- ▶ Adjust burner pressure to slightly below the burner pressure figure on the data plate (table 8). Loosen the locking screw (Fig. 11 [F]), and turn the knurled adjustment wheel (Fig. 11 [E]) clockwise to increase, or anticlockwise to decrease the pressure.
- ▶ Raise burner pressure to the burner pressure figure (See table 8).
- ▶ Tighten locking screw of knurled adjustment wheel (Fig. 11[F]).
- ▶ Turn off water heater, remove manometer and tighten burner test point captive screw.

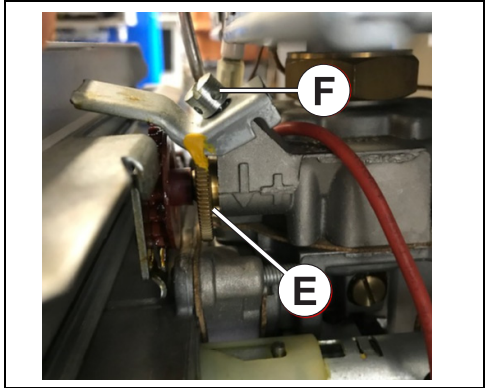

Fig. 11 Burner pressure adjustment

5.5 Conversion to a different type of gas

It is not recommended to convert these units to a different type of gas.

		Natural gas	LP gas
Max. Burner Pressure (kPa)	TF250	0.87 kPa	2.4 kPa

Table 8 Burner pressure

6 Commissioning 16 litres appliances



Commissioning **MUST** be carried out upon installation.

6.1 Before starting up the heater



CAUTION:

- ▶ Initial startup must be performed by an authorised gas fitter who will provide the customer with all the necessary information for optimum operation of the gas heater.

6.2 Remove the front cover

- ▶ Loosen the two knurled screws located on the rear side of the front panel.

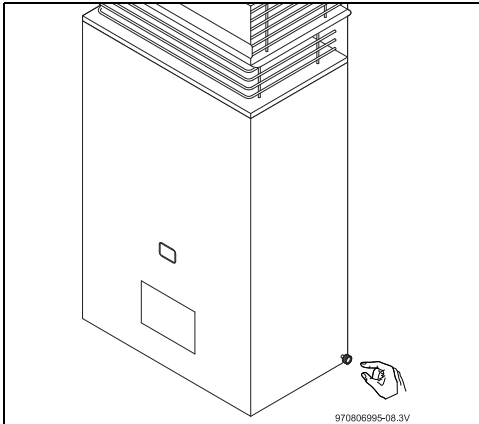

Fig. 12 Front cover removal

6.3 Water flow adjustment

- ▶ Open a hot tap fully that can provide at least 16L/min.
- or-
- ▶ Disconnect outlet and attach a ball valve and pipe to regulate and allow full flow.¹⁾
- ▶ Adjust the slotted screw on the base of the water valve (Fig. 13, [A]) to set the flow rate to 16L/min.

1) Alternate method hint.

- ▶ Turn screw clockwise to reduce pressure, anticlockwise to increase.

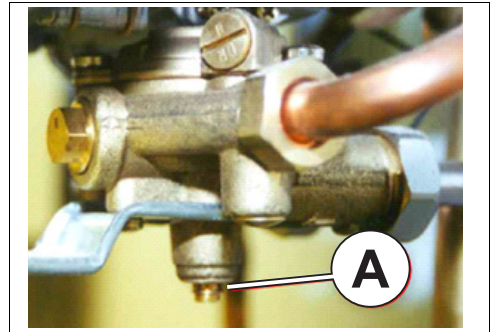

Fig. 13 Water flow adjustment screw

6.4 Inlet operating pressure adjustment

- ▶ Check the gas indicated on the data plate and label on the front flue panel is the same as to which the gas is connected.
- ▶ Turn off the gas to the appliance, remove the sealing screw of the pressure test point on the right hand side of the gas valve (Fig. 14, [B]) and attach a manometer.
- ▶ Turn on gas and light the pilot.

Static Pressures should be greater than or equal to the figures in table 9.

- ▶ Adjust the appliance regulator to achieve the figures in table 7 with the unit operating and several hot water taps open for full water flow through the unit.

If the operating inlet pressure cannot be achieved there may be an issue with the gas supply meter (NG), cylinder regulator (LPG), or pipe sizing (Ref AS/NZS5601). This must be resolved before proceeding.

- ▶ Remove manometer and refit sealing screw.



Measurements should be taken with unit operating and 16l/min running through the unit.
If possible all other gas appliances (ducted heating etc.) should be operating at the same time.

		Natural gas	LP gas
Inlet Pressure (kPa)	TF400	1.13 kPa	2.6 kPa

Table 9 Inlet pressure

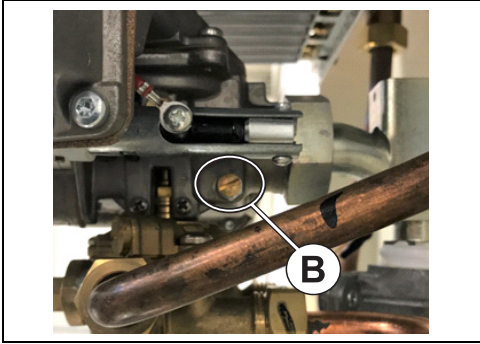

Fig. 14 Inlet measurement test point

6.5 Burner pressure adjustment

- ▶ Loosen the burner test point captive screw (→ Fig. 15, [D]).
- ▶ Connect a manometer to the burner pressure measuring point.

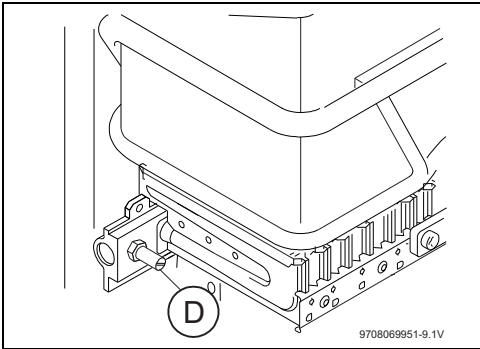

Fig. 15 Burner pressure test point

- ▶ Turn on gas to the appliance and relight the pilot.
- ▶ Turn on the water heater with full flow (16l/min).
- ▶ Using the appliance regulator, adjust the burner pressure to the burner pressure figure on the data plate (table 10).
- ▶ Turn off water heater, remove manometer and tighten the burner test point screw.

		Natural gas	LP gas
Max. Burner Pressure (kPa)	TF400	0.71 kPa	2.4 kPa

Table 10 Burner pressure

6.6 Thermostat calibration

- ▶ Using a flow cup, adjust the flow rate using the hot tap (or if using alternate method, use ball valve on outlet) to 6l/min.
- ▶ Allow unit to run for 1 minute and using a thermometer, measure the hot water temperature. Required temperature is 60 °C.
- ▶ To make adjustments, loosen the locking nut (fig. 16 [C]) and turn the thermostat adjustment nut (fig. 16 [D]) clockwise to decrease temperature, and anticlockwise to increase, to achieve the required 60 °C.
- ▶ Reduce the water flow rate to 3l/min, allow the unit to run for 1 minute, and ensure temperature does not rise above 63 °C. If it does, reduce temperature slightly by the adjustment nut.
- ▶ Tighten the locking nut.
The recommended operating temperature is 55 °C.
- ▶ Open the tap fully, reduce and adjust the flow rate using the water flow adjustment screw on the base of the water valve to achieve 55 °C.¹⁾
- ▶ Check all gas points with soap solution.

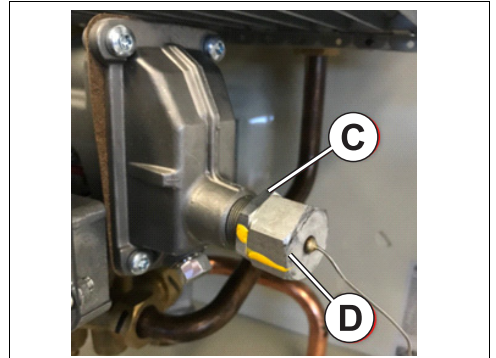

Fig. 16 Thermostat adjustment

6.7 Conversion to a different type of gas

It is not recommended to convert these units to a different type of gas.

1) 16l/min is based on a 25 °C temperature rise.

7 Operating instructions

7.1 Procedure to light 10 Litres appliance

7.1.1 Lighting the appliance

- ▶ Press button fully and keep it pressed.

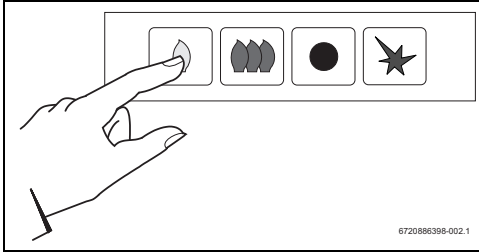

Fig. 17

- ▶ After a few seconds press igniter button.

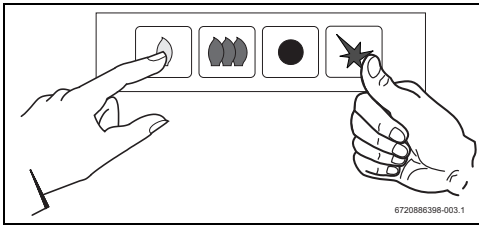

Fig. 18

- ▶ Release button after approx. 10 seconds. If the flame does not stay alight.
- ▶ Repeat the steps above. If the flame stay alight
- ▶ Press "ON" button.

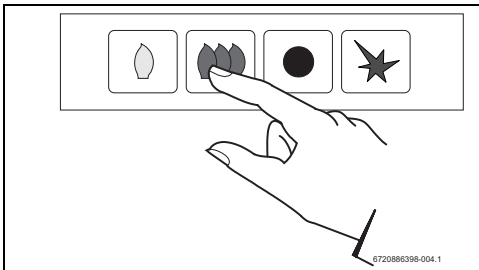

Fig. 19

7.1.2 Output control

For higher water temperature (Fig. 20).

- ▶ Slide to the right will give higher water temperature but use more gas.

For lower water temperature (Fig. 20).

- ▶ Slide to the left will give lower water temperature and use less gas.

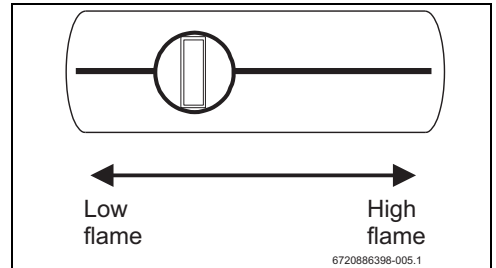

Fig. 20

7.1.3 Consumer temperature/flow adjustment

- ▶ Turn anti-clockwise. Increases flow and decreases water temperature (Fig. 21).

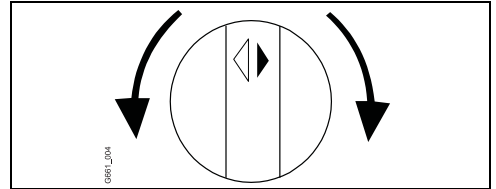

Fig. 21

- ▶ Turn clockwise. Decreases flow and increases water temperature.

Regulating the temperature to the minimum required value reduces energy consumption.



Turn hot water tap on fully when using.

7.1.4 Shutting OFF the appliance

If no hot water is to be drawn for a longer period of time.

- ▶ Press OFF button (Fig. 22).

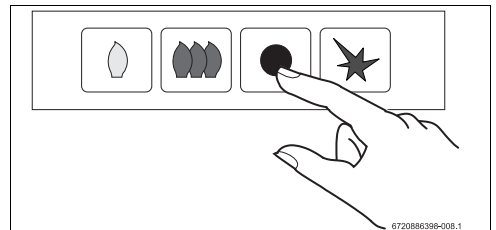

Fig. 22

7.2 Procedure to light 16 Litres appliance

7.2.1 Lighting the appliance

- ▶ Press button fully and keep it pressed.

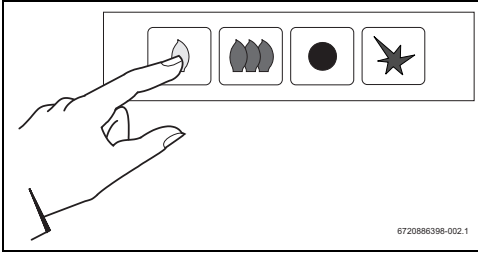

Fig. 23

- ▶ After a few seconds press igniter button.

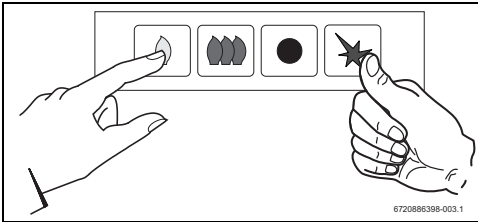

Fig. 24

- ▶ Release button after approx. 10 seconds.
If the flame does not stay alight.
- ▶ Repeat the steps above.
If the flame stay alight
- ▶ Press "ON" button.

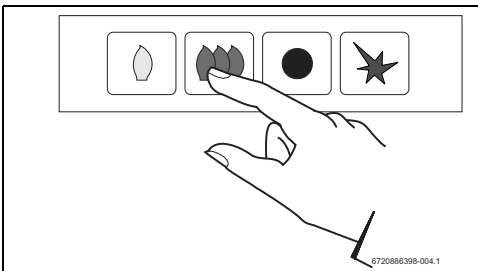

Fig. 25

7.2.2 Shutting OFF the appliance

If no hot water is to be drawn for a longer period of time.

- ▶ Press OFF button (Fig. 26).

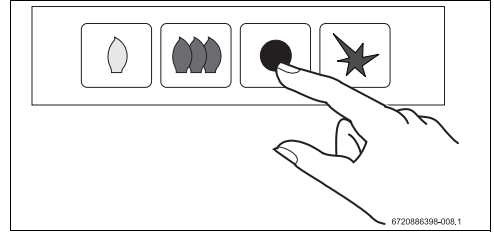



Fig. 26

8 Maintenance

To ensure ongoing performance and safety, we require the appliance be serviced every two years.

	<p>DANGER: Failure to perform maintenance procedures can lead to appliance malfunction, errors, service calls and loss of manufacturers warranty.</p>
--	--

► Only use original replacement parts.

	<p>Maintenance must only be performed by a qualified technician. Maintenance information is contained in a service manual available to licenced technicians upon request from Bosch.</p>
--	--

Service checklist		Done
1.	Water Valve	
1.1	Diaphragm, replace if required.	
1.2	Water throttle, greased, O-ring replaced if required.	
1.3	Water filter, cleaned, replace if required.	
1.4	Gland oring, greased, replace if required.	
1.5	Water governor, replace if required.	
1.6	Slow ignition, cleaned.	
2.	Gas Valve	
2.1	Pilot burner, cleaned.	
2.2	Main burner, injectors and venturies cleaned.	
2.3	Control buttons, greased.	
2.4	Piezo ignitor, greased.	
3.	Heat Exchanger	
3.1	Fins cleaned.	
3.2	Water connections tightened.	
4.	Gas pressure	
4.1	Burner pressures checked and adjusted.	

Table 11 Service checklist

9 Troubleshooting

9.1 Problem/cause/solution

Assembly, maintenance, and repairs must be performed by qualified technicians only. The following chart offers possible solutions to problems.

In most instances it is advisable to have a technician attend and

inspect the appliance.

Some further trouble shooting advice may be found at <http://www.bosch-thermotechnology.com.au>

Problem	Cause	Solution
Appliance does not light.	Gas supply turned off.	Check mains gas supply is turned on at mains / cylinder supply. (Are other gas appliances working?) Is the gas isolation valve is turned on at appliance.
	Appliance blocked.	Requires a service by a qualified technician.
Pilot lights but no main burner.	Main burner button not pushed in.	Push in, refer to relight section.
	Water throttle wound out too far.	Wind clockwise, refer to temperature adjustment section.
	Service required	Contact a qualified technician.
Smell of gas.	Gas leak.	Isolate gas supply to hot water unit. Contact a qualified technician.
Yellow flame/strong smell of gas in operation/presence of soot.	This is normally caused by blockages in the burner causing poor combustion.	All gas appliances required adequate air flow for combustion. The ingress of insects or dirt into the unit are not covered by warranty, as a manufacturing fault is not present. The unit will require cleaning and servicing at the owners cost.
	One of the causes of blockages is insects in the burner.	To minimise the chance of the issue recurring, a surface type insecticide can be used with care, consultation with a licensed pest controller is recommended. Isolate the valves to the appliance and spray surrounds with a surface spray. Leave for 15 minutes before relighting.

Table 12

Problem	Cause	Solution
Not hot enough	Insufficient gas supply (pressure/pipe sizing). Consumer gas and water controls. LPG gas cylinders may be empty/undersized.	Requires a service technician to inspect and test gas supply pipes/pressures and recommission. Adjust gas and water controls, refer to temperature adjustment section.
Temperature too hot in summer.	Incoming water temperature has increased with the ambient temperature.	Adjust gas control slide to the left.
Temperature too cold in winter.	Incoming water temperature has increased with the ambient temperature.	Adjust gas control slide to the left.
Fluctuation in hot water temperature.	Insufficient flow through the hot water unit. Tapware/shower head does not give sufficient flow or blocked. Appliance temperature set too high.	Change tapware to meet requirements. Check for blockages of aerators/restrictors. Adjust gas control slide to the left.
Reduced water flow.	Blocked tapware. Insufficient water supply pressure. Blocked water filter. Heat exchanger blocked (limescale).	Check for blockages. Requires a qualified technician to inspect supply pressures and water components of the hot water unit.
Hot water take a long time to reach hot taps.	Location of appliance.	The further from a hot tap, the longer it takes for hot water delivery. Locate appliance closer to hot tap.
No hot water	Pilot light off.	Relight pilot light, refer to relighting section.

Table 12

10 Environmental protection

Environmental protection is a basic company strategy of Bosch. The quality of our products, profitability and environmental protection are equal-ranking goals for us. Laws and regulations concerning environmental protection are strictly observed. We use the best possible technology and materials, under economic considerations, to protect the environment.

Packaging

We participate in the recycling program of the respective country to ensure optimal recycling. All of our packaging materials are environmental-friendly and can be recycled.

Old appliances

Old appliances contain valuable materials that should be recycled.

11 Water quality

All Bosch water heating appliances are constructed from high quality materials and components, and all are certified for compliance with relevant parts of Australian and New Zealand gas, electrical and water standards.

While Bosch water heaters are warranted against manufacturing defects, the warranty is conditional upon correct installation and use, in accordance with detailed instructions provided with the heater. In the case of the water supplied to the heater, it is important that the water quality be of acceptable standard.

The water quality limits/parameters listed in the water quality table are considered acceptable, and generally Australian and New Zealand suburban water supplies fall within these limits/parameters.

In areas of Australia and New Zealand where water may be supplied either fully or partly from bores, artesian wells, or similar, one or more of the important limits may well be exceeded and the heater could, therefore, be at risk of failure.

Where uncertainty exists concerning water quality, intending appliance users should seek a water analysis from the water supplying authority. In cases where it is established that the water supply does not meet the quality requirements of the water quality table, the Bosch warranty would not apply.

Water quality table

Maximum levels

pH	Saturation Index(LSI) (langelier)	Total Hardness	Chlorides	Sodium	Iron
6.5-9.0	+0.4 to -1.0 at 65 °C	200 mg/l	250 mg/l	180 mg/l	1 mg/l

Table 13

12 Warranty details

Robert Bosch (Australia) Pty Ltd Thermotechnology Division

Voluntary Repair or Replacement Warranty

All Bosch products are carefully checked, tested and certified to Australian and New Zealand standards.

Important Note: Mandatory Australian Consumer Law statement

If you have purchased your product in Australia, you should be aware that:

This warranty is provided in addition to other rights and remedies held by a consumer at law. Our goods come with guarantees that cannot be excluded under the Australian Consumer Law. You are entitled to a replacement or refund for a major failure and for compensation for any other reasonably foreseeable loss or damage. You are also entitled to have the goods repaired or replaced if the goods fail to be of acceptable quality and the failure does not amount to a major failure.

Important Note: New Zealand law

If you have purchased your product in New Zealand, you should be aware that:

This warranty is supplemental to any other rights and remedies you have under the Consumer Guarantees Act 1993 NZ, unless your purchase is made for commercial purposes, in which case Bosch excludes all consumer guarantees implied in the Consumer Guarantees Act 1993 NZ in respect of your product.

Warranty

Bosch warrants, at its option, to repair or replace your water heater or relevant part thereof (**Product**) if such Product are faulty or defective in manufacture or materials during the warranty period specified below.

The warranty period commences on the date of purchase. If the date of original purchase cannot be determined, then the warranty period will commence six (6) months after the date of manufacture stamped on the Product. Bosch may require evidence to verify the date of purchase.

This warranty only covers repair or replacement of defective Product (including labour costs where indicated). It does not cover:

- any costs incurred by the end user in normal or scheduled maintenance of the Product; or
- subject to any law to the contrary, any damage to property, personal injury, direct or indirect loss, consequential losses or other expenses arising from breach of this warranty. Any end user concerned with this exclusion should consider the "Important Note: Mandatory Australian Consumer Law statement" above

Warranty Period and Coverage

Bosch will provide warranty service for Product purchased and installed in Australia and New Zealand as follows.

Components	The period after purchase within which the fault must appear	What Bosch will do (see below for definitions)
Domestic Use (see below for definition)		
All components	Year [1 to 2]	Parts & Labour
Heat exchanger	Year [3 to 10]	Parts only
Commercial Use (see below for definition)		
All components	Year [1]	Parts & Labour
Heat exchanger	Year [1]	Parts only

Table 14

"**Parts & Labour**" means free of charge repair and/or replacement, including labour.

"**Parts only**" means a replacement heat exchanger, free of charge. All installation and repair labour costs are the responsibility of the owner.

Warranty details

"Domestic use" warranty period applies to Product installed to supply hot water for use by individuals in domestic dwellings. For Product used for all other uses, the commercial use warranty period will apply. This includes, without limitation, installations such as centralised or bulk hot systems, hotels, sporting complexes, caravan parks, laundry facilities, restaurants and cafes.

For "Parts only" warranty, the end user will be charged for service call costs and service technician fees in effecting the replacement.

For valid claims within "Parts & Labour" warranty periods, the end user will not be charged for costs associated with making a warranty claim, including service call costs, any service technician fees or the cost of replacement parts and freight, provided that:

- the Product is located within the usual operating area of an authorised service technician; and
- the Product has been installed according to the installation instructions so as to provide adequate service access

If the Product is not located within the usual operating area of an authorised service technician, the end user will be required to pay the service call costs associated with a service call under this voluntary warranty.

Notwithstanding the above, if the Product has not been installed in accordance with the installation instructions in regards to access, or has been otherwise installed in location where service access is difficult, the end user will be required to pay charges associated with the difficult access. This includes, but is not limited to, the removal of walls or doors to gain access and the use of specialised equipment to move the Product or components to safe working levels. Where the Product cannot be safely accessed, Bosch may refuse to service the Product under this voluntary warranty.

For invalid claims under this voluntary warranty, the end user will be liable for the costs of making the warranty claim including any service call costs.

Warranty Conditions

This voluntary warranty is subject to the following conditions:

- The Product must have been installed and correctly commissioned by an authorised and licensed installer in compliance with applicable Australian Plumbing and Gas Standards. Proof may be required of correct commissioning of the Product (such as certificate of compliance). Claims for failures due to incorrect installation or commissioning are not covered under this voluntary warranty and may be rejected by Bosch.
- Where a Product or part thereof is replaced or repaired under this voluntary warranty, the balance of the original voluntary warranty will apply. The replacement Product or part does not carry a new voluntary warranty.
- The Product must have its original serial numbers and rating labels intact.
- The warranty does not extend to any Product that have been completely or partially disassembled.
- These warranty terms cannot be amended except in writing by an authorised officer of Bosch.
- The warranty only applies to Product installed for an end user in Australia or New Zealand and purchased from Bosch or from a reseller where the Product have been originally sold by Bosch.
- Any claim made under this voluntary warranty meets the requirements set out below in the "How to Make a Warranty Claim" section.

Warranty Exclusions

This warranty will not apply to a defect or fault to the extent to which it arises:

- due to storage, handling or installation of the Product otherwise than in accordance with instructions provided for the Product by Bosch or without reasonable care, including installation of a Product which is of inappropriate size or type for the intended purpose;
- due to operation, use or maintenance of the Product otherwise than in accordance with instructions provided for the Product by Bosch or without reasonable care, including use of the Product with faulty or unsuitable plumbing, water pressure, power or gas supply;
- due to accidental damage or use of the Product for a purpose or in environmental conditions for which the Product were not designed or sold, or use of the products outside the specified or normal operating ranges for such Product.
- as a result of changes which occur in the condition or operational qualities of the Product due to climate or other environmental influence, foreign material contamination or water entry or as a result of exposure to excessive heat or solvents or because of use of non-potable water or bore water in the Product or damage as result of an Act of Nature including but not limited to storms, fires, floods and lightning strikes;
- from normal wear and tear or when replacement or repair of parts would be part of normal maintenance or service of the Product or where the damage is only to surface coating, varnish or enamel;

- as a result of repairs, alterations or modifications to the Product which have been performed by a person who is not suitably qualified and experienced to perform works on the Product; or
- from the use of any spare parts not manufactured, sold or approved by Bosch in connection with the repair or replacement of Product.

This voluntary warranty does not apply to damage that has been caused by continued use of a Product after it is known, or would have been known with regular servicing, it is defective.

Failure to service Product in accordance with recommendations in instruction manuals for Product may result in a warranty claim under this voluntary warranty being rejected by Bosch. Bosch alerts end users that instruction manuals for Product contain specific recommendations for servicing and safety checks to be carried out on Product.

Table 15

Wrong Deliveries and Transit Damage

Wrong deliveries, incorrect or damaged packing and transit damage claims are not warranty claims. Such cases should be directed to Bosch's Customer Service line in Australia on ph: 1300 307 037 or in New Zealand on ph: 0800 543 352.

How to Make a Warranty Claim

If a Product fails within the warranty period, the end user must stop using the Product and make a claim as soon as possible, in any event before the end of the Warranty Period (see Deadlines for Submitting Warranty Claims below).

To make a warranty claim under this voluntary warranty, call the Bosch Customer Contact Centre (in Australia on ph: 1300 307 037 or in New Zealand on ph: 0800 543 352). Please be ready to provide the model and serial number, date of installation, purchase details and a full description of the problem. Alternatively, for claims in Australia, you can post details of your claim to Robert Bosch (Aust) Pty Ltd, Attn TT Warranty Department, Locked Bag 66, Clayton Sth, Victoria, 3169. Claims received by post will take longer to process and we encourage you to call. Bosch may refer you to one of its Bosch Warranty Authorised Service Dealers.

Proof of purchase and purchase date, as well as proof of installation and proper commissioning by a licensed installer, may be required by Bosch or an authorised service technician.

All warranty service calls will be conducted by an authorised service technician during normal business hours. Bosch will not accept claims under this voluntary warranty for attendance and repair of the Product by third parties not authorised by Bosch.

Deadlines for Submitting Warranty Claims

Bosch aims to rectify genuine quality problems as a priority. This is generally achieved by investigating why defective products have failed and by introducing immediate corrective action measures to prevent re-occurring warranty failures. It is therefore critical that all warranty claims are promptly submitted to Bosch as soon as the product fails, and in any event before the end of the warranty period.

Product Liability and Product Safety

Bosch should be informed immediately about any potential product safety concerns within and outside the warranty period. Bosch is well aware of its product liability and product safety obligations and responsibilities. It is our aim to ensure appropriate product safety standards are met in order to avoid injury, loss and damage caused by defects in any Product.

Privacy

Bosch is required to seek personal information from an end user who seeks to make a claim under this warranty.

Such personal information may be used by Bosch and/or any authorised service technician (who is authorised to process warranty claims and/or carry out warranty repairs on behalf of Bosch) for the purpose of processing such warranty claim and also for the provision of customer support and further information about Bosch's products and services (Purpose).

If an end user does not wish to provide Bosch and/or its authorised service technician with personal information, Bosch may be unable to process the end user's warranty claim or to provide the end user with additional customer support, services and information.

Warranty details

Bosch is committed to protecting the privacy of personal information and will act in compliance with applicable privacy laws, including the National Privacy Principles under the Australian Privacy Act 1988 (Cth) (as amended) and New Zealand's Information Privacy Principles described in the Privacy Act 1993 (NZ).

Bosch takes security measures in order to protect any personal information collected in the warranty claim process against manipulation, loss, destruction, access by unauthorized persons or unauthorized disclosure.

Bosch will not disclose any personal information to third parties other than for the Purpose or except as required by law.

An end user has the right to access the personal information Bosch or its authorised service technician hold about them. The end user can request to see, change or modify the personal information held about them, or withdraw consent for its usage, by contacting Bosch at the Bosch Contact Details below.

Bosch Contact Details

This warranty is offered by Robert Bosch (Australia) Pty Ltd (ACN 004 315 628) of 1555 Centre Road, Clayton, Victoria 3168. Please call the Customer Contact Centre on 1300 30 70 37 in Australia or 0800 543 352 in New Zealand if you have any queries in relation to this warranty or contact us using the online form at www.bosch-thermotechnology.com.au.

Notes

Robert Bosch (Australia) Pty Ltd
Thermotechnology Division
1555 Centre Road
Clayton Victoria 3168

Australia
Phone: 1300 30 70 37
Fax: 1300 30 70 38
www.bosch-thermotechnology.com.au

New Zealand
Phone: 0800 54 33 52
Fax: 0800 54 33 55
www.bosch-thermotechnology.co.nz